

AC15S-320

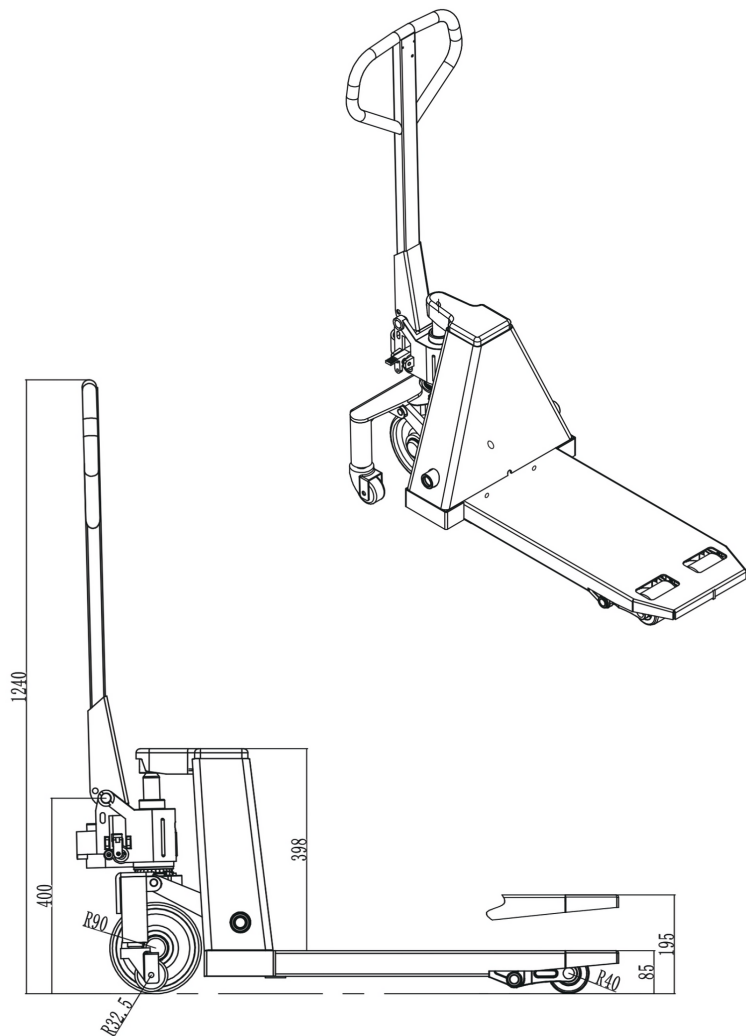

Especificaciones técnicas:

Modelo	AC15S-320	
Capacidad	kg	1500
Altura mínima de la horquilla	mm	85
Altura máxima de la horquilla	mm	195
Longitud de la horquilla	mm	670
Anchura de horquilla	mm	320
Rueda	mm	180 X 50
Rodillo delantero	mm	80 X 94
Ruedas estabilizadoras	mm	65 X 20
Peso	kg	63

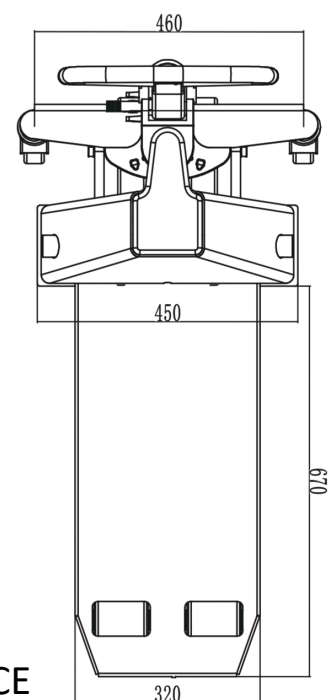

TODOS NUESTROS PRODUCTOS TIENEN LA CERTIFICACIÓN CE

