

Transpaleta manual 5t

- Transpaleta diseñada para moverla fácilmente a pesar de su peso.
- Ruedas y rodillos dobles de hierro.



Especificaciones técnicas:

MODELO	HP50S		
Capacidad	Kg	5000	
Elevación máxima horquillas (H)	mm	200	
Altura mínima horquillas (h)	mm	90	
Largo horquillas (l)	mm	1150	
Ancho exterior horquillas (B)	mm	580	
Ancho horquilla individual (b)	mm	210	
Medidas (LxWxH)	mm	1546x588x1300	
Peso propio	Kg	192	

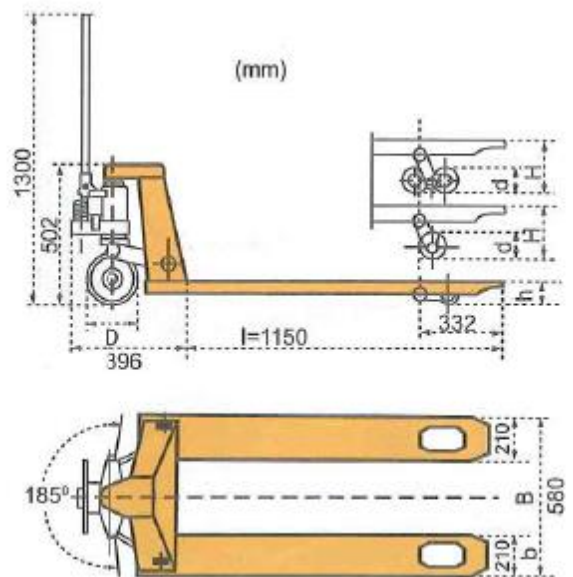

TODOS NUESTROS PRODUCTOS TIENEN LA CERTIFICACIÓN CE



